

# MODBUS RTU COMMUNICATION MODULE

For Diehl Metering SHARKY 775 and SCYLAR INT 8

User guide

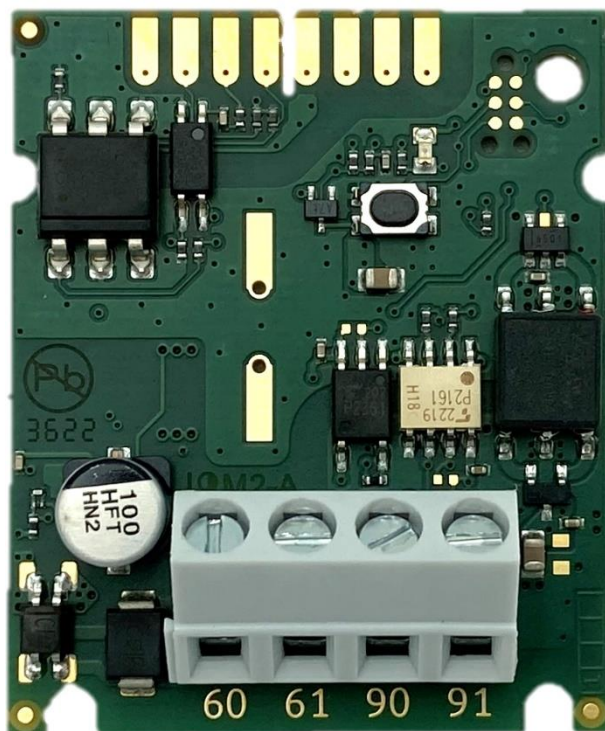

Diese  
Anleitung ist  
dem Endkunden  
auszuhändigen.  
This guide must be given  
to the end consumer.  
Ce guide doit être donné  
au client final.  
Esta guía se debe dar  
al cliente final.

## Table of contents

1	INTRODUCTION.....	3
2	SAFETY INSTRUCTIONS .....	3
2.1	DISPOSAL OF WAST EQUIPMENT.....	4
3	TECHNICAL INFORMATION.....	4
4	MODULE INTERFACES .....	5
5	MODULE INSTALLATION.....	5
5.1	INSTALLATION IN THE METER .....	5
5.2	POWER SUPPLY WIRING .....	7
5.2.1	POWER CABLE .....	7
5.2.2	CONNECTION SCHEMATIC.....	7
5.3	EIA-485 NETWORK CHANNEL WIRING .....	8
5.3.1	EIA-485 CABLE.....	8
5.3.2	WIRING DIAGRAMS.....	9
5.3.3	NETWORK TYPOLOGY .....	9
5.4	FIRST POWER-UP.....	11
5.5	CLOSING THE METER HOUSING .....	11
6	MODBUS RTU INTERFACE .....	11
6.1	MODULE ADDRESSING .....	12
6.1.1	AUTOMATIC SLAVE ID .....	13
6.2	MODBUS REGISTERS.....	14
6.2.1	MEASUREMENT DATA REGISTER.....	15
6.2.2	CONFIGURATION REGISTERS .....	17
6.2.3	INFORMATION REGISTERS .....	18
6.3	UNIT ID TABLE .....	18
6.4	CALCULATION EXAMPLE.....	19
6.5	PERIODIC LOG FUNCTIONALITY 0 .....	20
6.6	ERROR CODES.....	21
6.7	MODBUS CONFIGURATOR SOFTWARE .....	22
7	RESTORE TO DEFAULT SETTINGS.....	22
8	TROUBLESHOOTING GUIDE .....	22
9	DECLARATION OF CONFORMITY.....	24

## 1 INTRODUCTION

The Modbus RTU communication module is designed to read data from SHARKY 775 compact ultrasonic energy meters or SCYLAR INT 8 energy calculators manufactured by Diehl Metering, and to share data over the Modbus RTU network using the EIA-485 (formerly RS-485) channel.

The module is designed to be installed inside housing of the meter in dedicated extension card slot. The module periodically reads the data from the meter using EN 13757-3 standard (known as M-Bus). The data update rate can be defined by user.

The purpose of the user guide is to explain how to safely use this product. The document presents how to correctly install the module, how to properly connect power supply and communication network to the module and how to configure the module to work within Modbus RTU network. In addition, for easy product use, this document describes how to read and understand the data from the module.

**NOTE:**

Please read this document carefully before using the product. Important information can be found in each section.

---

## 2 SAFETY INSTRUCTIONS

Follow the safety instructions below to ensure your personal safety and protect your equipment and working environment.

**WARNING:**

Installation and electrical connection of the product may only be carried out by suitably qualified and trained installers who are authorized to install electrical equipment.

---

**DANGER:**

Do not touch any parts of product during installation work when the power supply voltage is on. **Risk of serious injuries or death** and/or at least product damage! Turn of the power supply voltage during product installation.

---

**EDS CAUTION:**

This product is sensitive to electrostatic discharge (ESD). It is recommended that standard static precautions should be taken in handling and assembly of this module to prevent damage which may be induced by ESD. Failure to follow proper handling and installation procedures described in this document can cause damage. ESD damage can range from performance degradation to device failure for which Diehl Metering is not responsible.

---

## 2.1 DISPOSAL OF WAST EQUIPMENT



**WEEE CAUTION:**

This product is electronic equipment and it must not be disposed of with other domestic waste. It must be separately collected and recycled as waste electrical and electronic equipment (WEEE) according to currently valid legislation. The separate collection and recycling of waste equipment will help to conserve natural resources and ensure that it is recycled in a manner that protects human health and the environment.

## 3 TECHNICAL INFORMATION

Parameter	Value
Operating voltage	12 - 24 V AC/DC ± 10%
Maximum input power	500 mW
Communication type	EIA-485 (galvanically isolated, 1/8 Unit Load)
Communication protocol	Modbus RTU
Communication parameters	Transmission speed (bits per second): 1200, 2400, 4800, 9600, 14400, 19200, 38400, 56000, 57600, 115200 Number of data bits: 8 Parity bit: even, odd, none Number of stop bits: 1, 2
Operating temperature	0 ... +55°C
Storage temperature	+5 ... +35°C
Dimensions	37.2 mm x 44.8 mm x 16.2 mm
Weight	13 g
Weight with bag	15 g
Packaging	Antistatic bag



**DANGER:**

Use only a SELV power supply.

**Risk of serious injuries or death** and/or at least product damage! The product is designed to use with one power supply module per one product for safety reason.

## 4 MODULE INTERFACES

Interface	Description
<b>Meter</b>	Internal connection with Diehl Metering flexible ribbon cable (P/N: 3013651)
<b>Power supply</b>	Screw terminal 60 and 61 (without polarity)
<b>EIA-485</b>	Screw terminal 90 (+) and 91 (-).
<b>Status button</b>	Check device status and restore default settings.
<b>Status LED</b>	Status of transmission via Modbus RTU network and confirmation of restoration of default device parameters. Status LED lights up when status button is pressed.

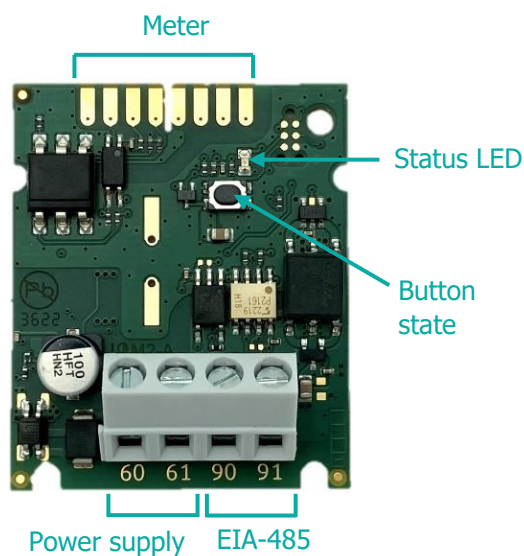

Figure 1 Module interfaces

## 5 MODULE INSTALLATION

The module can only be installed in the following Diehl Metering meters:

- SHARKY 775 compact ultrasonic energy meter
- SCYLAR INT 8 energy calculators

No other meters are supported.

### 5.1 INSTALLATION IN THE METER

SHARKY 775 and SCYLAR INT 8 meters have two slots for extension modules. Modbus RTU Communication Module can be installed in one of them. These slots are marked by number 1 and 2 in the picture below. Each slot has fixing lugs to help installing extension module and stabilize its position.

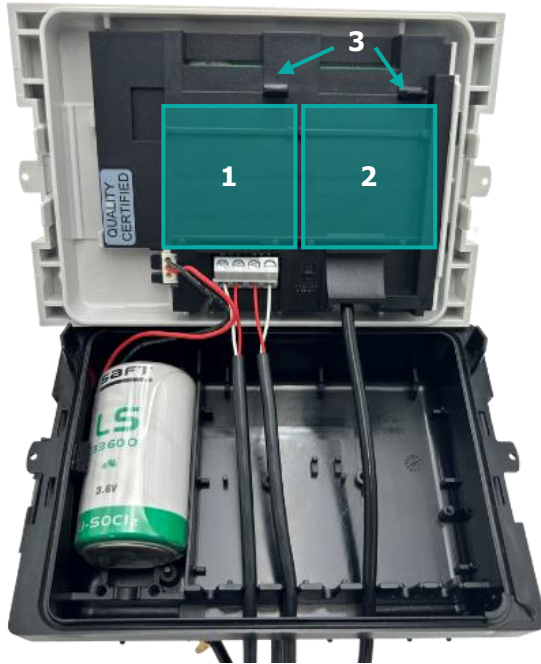

- 1. Location 1
- 2. Location 2
- 3. Module mounting brackets

Figure 2 Internal view of the meter



**ESD CAUTION:**

This product is sensitive to electrostatic discharge (ESD). It is recommended that standard static precautions should be taken in handling and assembly of this module to prevent damage which may be induced by ESD. Failure to follow proper handling and installation procedures described in this document can cause damage. ESD damage can range from performance degradation to device failure for which Diehl Metering is not responsible.

Module installation steps :

1. Open the meter housing by releasing the latches and remove the front panel - refer to the installation and user guide for SHARKY 775 Ultrasonic Compact Energy Meter or SCYLAR INT 8 calculator.
2. Find the right location
3. Place the module in one of the slots. The positioning elements must match the cuts on the module.
4. Push the module towards the meter front panel to lock it in place with the mounting bracket.
5. Check that the module is securely installed in the slot.  
Connect the module to the meter using a ribbon cable (see image below).



Figure 3 Module installed in the meter

**NOTE :**

For more information on how to install and combine extension modules, see the SHARKY 775 and SCYLAR INT 8 installation guides.

---

## 5.2 POWER SUPPLY WIRING

The module contains a screw terminal block for connecting the power supply, marked 60 and 61. The module's operating voltage is between 12 and 24 V AC/DC  $\pm$  10%.

The connection to the SELV power supply unit is polarity-independent and galvanically isolated from the meter.

---

**DANGER :**

Use only a SELV power supply.

**Risk of serious injuries or death** and/or at least product damage! The product is designed to use with one power supply module per one product for safety reason.

---

### 5.2.1 POWER CABLE

The screw terminal block is suitable for wires up to 2.5 mm<sup>2</sup>.

For example, you can use a 2 x 0.75<sup>2</sup> mm two-wire cable.

---

**NOTE :**

The cable length between the module and the power supply must be less than 1 meter.

---

### 5.2.2 CONNECTION SCHEMATIC

**DANGER :**

Do not touch any parts of product during installation work when the power supply voltage is on. **Risk of serious injuries or death** and/or at least product damage! Turn off the power supply voltage during product installation.

---

The connection of the module to the power supply is shown in the diagram below.

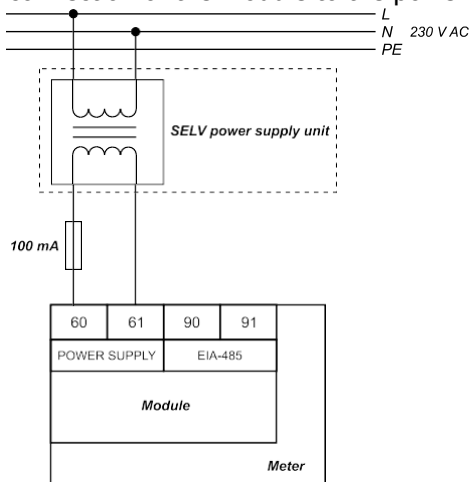

Figure 4 Power supply connection



Figure 5 Example of power supply wiring

Connection steps :

1. Pass the power supply cable through the wire protection sleeve on the underside of the meter.
2. Connect the cable to the module's power terminals (see picture above).



**WARNING:**

Do not connect power supply wires to the EIA-485 interface connectors 90 and 91. It can damage the module!



**NOTE :**

It is recommended to use 100 mA fuse between SELV power supply unit and the module.

### 5.3 EIA-485 NETWORK CHANNEL WIRING

Modbus RTU Communication Module contains two-wire terminal for connecting network cable to EIA-485 (formerly RS-485) channel. The module has galvanically isolated EIA-485 interface. The EIA-485 interface is polarity dependent. Non-inverting signal shall be connected to terminal marked as 90 (+) and inverting signal shall be connected to terminal marked as 91 (-). The maximum EIA-485 channel length is 1,200 m.

#### 5.3.1 EIA-485 CABLE

Terminals are suitable for wires up to 2.5 mm<sup>2</sup>. To connect the module with EIA-485 bus use two-wire twisted-pair cable with nominal characteristic impedance 120 Ω without or with shield. If shielded cable is used, shield shall not be connected or grounded.

Recommended cable is BELDEN 9841 1x2x24AWG shielded twisted-pair or similar.



### 5.3.2 WIRING DIAGRAMS

EIA-485 wiring is shown in the images below.

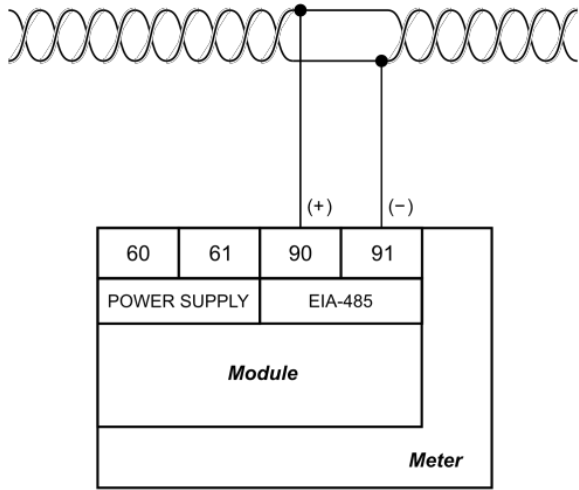

Figure 6 Example of a correctly wired module



Figure 7 Connecting the EIA-485 interface

Connection steps:

- 1 Guide the EIA-485 cable through the wire protecting sleeve into the bottom part of the meter.
- 2 Connect the cable to the EIA-485 terminals on the module (see picture above).

### 5.3.3 NETWORK TYPOLOGY

The EIA-485 standard requires that nodes be connected only in a bus topology network. In bus topology, devices can be connected to the EIA-485 transmission line via stubs. Stubs should be as short as possible to limit signal reflections.

The transmission line must always be terminated at both ends of the bus to avoid reflections that could cause data errors.



Bus topology in the EIA-485 network channel

Proper termination requires the matching of the terminating resistors to characteristic impedance of the transmission line. There are two termination types for EIA-485 channel: standard termination and termination with fail-safe biasing. Standard termination can be used in low-noise domestic environment only. In standard termination, each end of bus should be terminated with 120 Ω resistor.

Termination with fail-safe biasing is required in industrial environment and it is highly recommended by manufacturer. When network distance is below 100 m fail-safe biasing at one end of the bus is often sufficient. The other end of the of the bus shall be terminated with 120 Ω resistor. For network distance longer than 100 m fail-safe biasing at both ends of the bus is necessary.

Fail-safe biasing circuit is a resistive voltage divider which consists of a pull-up, terminator, and pull-down resistors. It provides the necessary differential bus voltage  $V_{(+)(-)}$ , when no device transmits data over the bus. In addition, sufficient noise margin should be added when the device is operated in harsh industrial environments. To ensure sufficient noise margin, the value of the receiver input voltage  $V_{(+)(-)}$  must be the sum of the receiver input threshold  $V_{IT\_max}$  and maximum permissible noise margin  $V_{NOISE}$ .

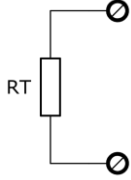
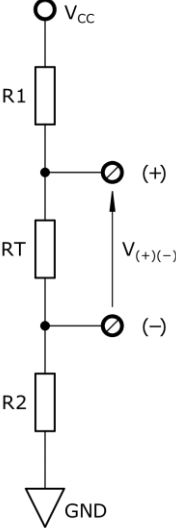
Termination type	Diagram	Values
Standard termination		$R_T = 120 \Omega$
Termination with safety polarization		$R_T = 138 \Omega; \pm 5\%; \frac{1}{4} W$ $R_1, R_2 = 470 \Omega; \pm 5\%; \frac{1}{4} W$ Assumptions: <ul style="list-style-type: none"> <li>• Unique fail-safe network</li> <li>• <math>V_{CC\_min} = 4.75 V</math></li> <li>• <math>V_{NOISE} = 100 mV</math></li> <li>• <math>V_{IT\_max} = 200 mV</math></li> <li>• <math>V_{(+)(-)} = V_{IT\_max} + V_{NOISE} = 300 mV</math></li> </ul>

**NOTE:**

Modbus RTU Communication Module  $\frac{1}{8}$  Unit Load (UL) transceiver is used. Termination with fail-safe biasing reduces the maximum number of bus loads due to additional common-mode loading. For network without fail-safe biasing the maximum number of  $\frac{1}{8}$  UL transceivers is 256. For single fail-safe network the maximum number of  $\frac{1}{8}$  UL transceivers is 51. For more information about EIA-485 network termination please refer to External Fail-Safe Biasing of RS-485 Networks application notes by Renesas Electronics Corporation.



### 5.4 FIRST POWER-UP

The first start-up of the Modbus RTU communication module must be performed before closing the meter housing. Please refer to the following table for the necessary steps:

Step	Action	Expected result
1	Turn on power supply	Status LED flashes once.
2	Press the module status button	Status LED lights up when button is pressed
3	Read any Modbus register using the Modbus RTU application with default communication parameters.	The status LED flashes during communication, and the response with the appropriate data from the module is received by the Modbus application.

If all three tests are passed, the module is ready for use and the meter housing can be closed. If one of the tests fails, see Troubleshooting chapter 8 for more information.

### 5.5 CLOSING THE METER HOUSING

To close the meter correctly with the module inside, follow the steps below:

1. Check that the module is correctly installed in the expansion slot.
2. Make sure all cables are in the correct position and securely screwed down.
3. If there are several loose cables inside the meter housing, pull them towards the outside of the meter.
4. Place the front panel on the bottom of the meter housing, starting from the left edge of the housing.
5. Close the meter housing using the side latches.



Figure 8 Closing the meter housing starting from left edge then closing the meter housing with the side latches

## 6 MODBUS RTU INTERFACE

The Modbus is the most widely used network protocol in industrial environment. It is often used to connect a supervisory computer with a remote terminal unit (RTU) in supervisory control and data acquisition (SCADA) systems. Modbus RTU is the most common implementation available for Modbus using EIA-485 (formerly RS-485) channel.

Modbus RTU is used to establish master-slave communication between electronic devices. That means that it is based upon request/reply mechanism. Transmission is initialized by master and it sends the request message which contains address of slave (called Slave ID) - address of device requested to

answer and a function code - specific request for particular data. The slave in response sends the requested data. Modbus RTU Communication Module is slave device.

Modbus RTU is used a compact, binary representation of the data for protocol communication. Modbus RTU Communication Module store the data in object types called registers - Input register and Holding Registers which have 16 bits size. Registers provided by this device can be found in 6.2 Modbus registers.

Modbus RTU Communication Module supports following functions (function codes):

- Read Holding Registers (0x03)
- Read Input Registers (0x04)
- Write Single Register (0x06)
- Write Multiple Registers (0x10)

To make communication with Modbus RTU Communication Module simple, measurement data from the meter are stored by the module in both types of registers - holding registers and input registers. Therefore measurement data can be read by using function code 0x03 or 0x04. To modify module configuration, function code 0x06 or 0x10 should be used.

---



**NOTE:** The Communication Module sends data with the most significant register first and the most significant byte first ("byte swap" or "word swap" are not used to decode data).

---

The development and update of Modbus protocols has been managed by the Modbus Organization. For more information about Modbus standard please refer to following documents - *Modicon Modbus Protocol Reference Guide* and *MODBUS over Serial Line - Specification and Implementation Guide*.

## 6.1 MODULE ADDRESSING

A single Modbus RTU network on an EIA-485 channel (called a Modbus bus) can contain a single master and up to 247 slaves. The master - usually a PC - has full control of communication and can make read or write requests. The slave device can only respond to requests, and cannot actively poll other devices on the network. Each slave device on the network must have its own unique address, the *slave ID*. The slave ID can be assigned in the range 1 to 247. Address 0 is reserved for *broadcast* messages. The master node has no specific address assigned.

---



**NOTE:** Please take care not to setup two slave devices with the same Slave ID, it will lead to frame collisions on Modbus bus.

---

The master uses the slave ID to correctly address a particular device on the Modbus network. Slave ID 0 is used to issue a *broadcast* command to all devices on the bus. Note that slave nodes do not respond to *broadcast* messages.

Slave address	Function
0	Broadcast
1 ... 247	Available slave addresses
248 ... 255	Reserved addresses

### 6.1.1 AUTOMATIC SLAVE ID

Automatic Slave ID functionality is supported by Modbus RTU Communication Module. This option allows the module to set Modbus Slave ID basing on secondary address set in connected meter.



**NOTE:**

Secondary address is default set to meter serial number which is presented on meter enclosure.

It is possible to read current setting of secondary address in meter by pressing button located on meter enclosure in right sequence. From main loop of information window we must go to Info loop by pressing the button two times for a long time (more than 3 seconds). Enter to Info loop will be signaled by number 3 at bottom line of the display. Next, pressing the button for a short time (up to 3 seconds), we enter to information screen called shortly *SEC\_Adr*. After waiting 2 seconds, on the display will be presented current value of secondary address. Display state with secondary address is presented below:



Figure 9 Secondary address displayed on meter screen

For more information on SHARKY 775 or SCYLAR INT 8 interfaces, please refer to the meter documentation.

Special care is taken to ensure that only one slave identification number is generated. The algorithm in the figure below shows the details of slave identification when the automatic identification feature is activated.

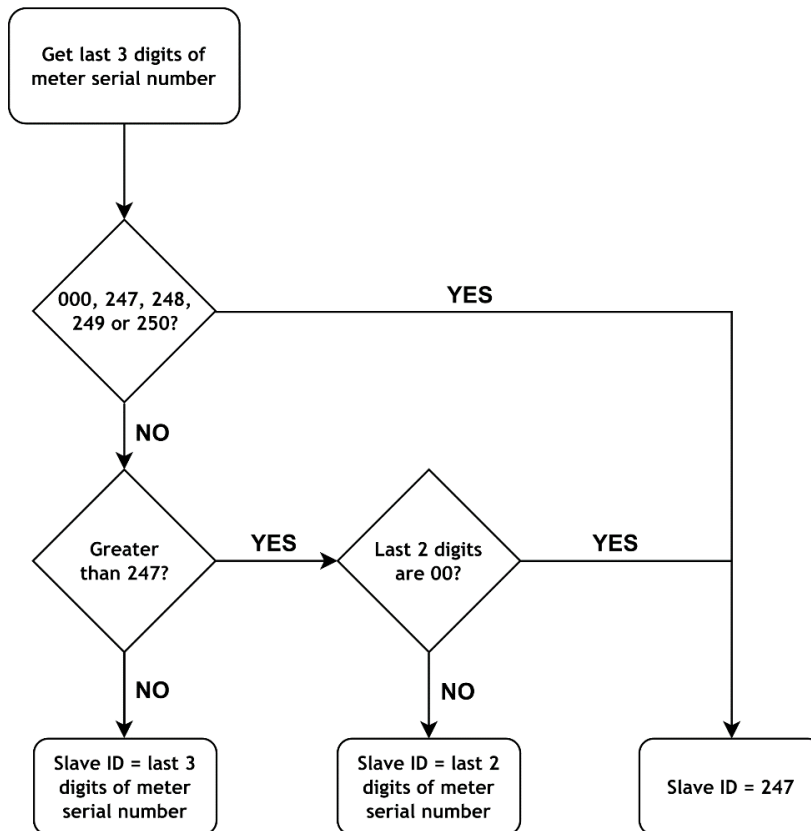

Figure 10 Automatic module addressing algorithm

Automatic addressing table based on meter serial number :

Last 3 digits of meter serial number	Module address ( <i>Slave ID</i> )	Last 3 digits of meter serial number	Module address ( <i>Slave ID</i> )
#### #000	247	#### #296	96
#### #001	1	#### #297	97
#### #002	2	#### #298	98
...	...	#### #299	99
#### #240	240	#### #300	247
#### #246	246	#### #301	1
#### #247	247	#### #302	2
#### #248	247	...	...
#### #249	247	#### #398	98
#### #250	247	#### #399	99
#### #251	51	#### #400	247
#### #252	52	#### #401	1
...	...	...	...



**NOTE:**

The automatic *slave ID* addressing option is enabled by default.

The automatic *slave ID* addressing function is deactivated or activated via the data in Modbus register 41001 (Modbus address 1000), as described in the table below.

Automatic Slave ID functionality	Register value (high byte)	Register value (low byte)	Description
Disabled	0 (0x00 hex)	Address range 1 to 247 (0x01 to 0xF7 in hexadecimal)	Static Slave ID
Enabled	1 (0x01 hex)	Address range 1 to 247 (0x01 to 0xF7 in hexadecimal)	Slave ID will be updated after first readout of heat meter data

## 6.2 MODBUS REGISTERS

The Modbus RTU communication module supports two types of registers

- *Holding* registers read and write (4####)
- *Input* registers write only (3####)

Each register has a size of 16 bits (2 bytes) and a unique address. Measurement data from the counter is stored by the module in two types of register - Holding Registers and Input Registers.

**NOTE:**



There are two conventions for addressing registers in Modbus. Be careful when accessing registers. The addressing method may depend on the application used. Some applications may use only the long format (Modbus Register), while others may use the short format (Modbus Address).

To obtain the Modbus address, subtract offset 40001 (for holding registers) or 30001 (for input registers) from the Modbus register.

For example, to obtain the Modbus address for reading the volume value: 40011 (Modbus register) - 40001 (offset for holding registers) = 10 (Modbus address).

**6.2.1 MEASUREMENT DATA REGISTER**

Description	Modbus register	Type register	Modbus address	Type of data
Energy	30001 or 40001	Input or Holding	0	Int32
Energy (Coefficient)	30003 or 40003	Input or Holding	2	UInt16
Energy (Unit)	30004 or 40004	Input or Holding	3	8 char ASCII
Energy (Unit code)	30008 or 40008	Input or Holding	7	UInt16
Energy (Float)	30009 or 40009	Input or Holding	8	IEEE 754
Volume	30011 or 40011	Input or Holding	10	Int32
Volume (Coefficient)	30013 or 40013	Input or Holding	12	UInt16
Volume (Unit)	30014 or 40014	Input or Holding	13	8 char ASCII
Volume (Unit code)	30018 or 40018	Input or Holding	17	UInt16
Volume (Float)	30019 or 40019	Input or Holding	18	IEEE 754
Power	30021 or 40021	Input or Holding	20	Int32
Power (Coefficient)	30023 or 40023	Input or Holding	22	UInt16
Power (Unit)	30024 or 40024	Input or Holding	23	8 char ASCII
Power (Unit code)	30028 or 40028	Input or Holding	27	UInt16
Power (Float)	30029 or 40029	Input or Holding	28	IEEE 754
Flow	30031 or 40031	Input or Holding	30	Int32
Flow (Coefficient)	30033 or 40033	Input or Holding	32	UInt16
Flow (Unit)	30034 or 40034	Input or Holding	33	8 char ASCII
Flow (Unit code)	30038 or 40038	Input or Holding	37	UInt16
Flow (Float)	30039 or 40039	Input or Holding	38	IEEE 754
Start temperature	30041 or 40041	Input or Holding	40	Int16
Flow temperature (Unit)	30042 or 40042	Input or Holding	41	8 char ASCII
Start temperature (Unit code)	30046 or 40046	Input or Holding	45	UInt16
Flow temperature (Float)	30047 or 40047	Input or Holding	46	IEEE 754
Return temperature	30049 or 40049	Input or Holding	48	Int16
Return temperature (Unit)	30050 or 40050	Input or Holding	49	8 char ASCII
Return temperature (Unit code)	30054 or 40054	Input or Holding	53	UInt16
Return temperature (Float)	30055 or 40055	Input or Holding	54	IEEE 754
Temperature difference	30057 or 40057	Input or Holding	56	Int16
Temperature difference (Unit)	30058 or 40058	Input or Holding	57	8 char ASCII
Temperature difference (Unit code)	30062 or 40062	Input or Holding	61	UInt16
Temperature difference (Float)	30063 or 40063	Input or Holding	62	IEEE 754
Tariff 1 - Energy	30065 or 40065	Input or Holding	64	Int32

Description	Modbus register	Type register	Modbus address	Type of data
Tariff 1 - Energy (Coefficient)	30067 or 40067	Input or Holding	66	UInt16
Tariff 1 - Energy (Unit)	30068 or 40068	Input or Holding	67	8 char ASCII
Tariff 1 - Energy (Unit code)	30072 or 40072	Input or Holding	71	UInt16
Tariff 1 - Energy (Float)	30073 or 40073	Input or Holding	72	IEEE 754
Tariff 1 - Volume	30075 or 40075	Input or Holding	74	Int32
Tariff 1 - Volume (Coefficient)	30077 or 40077	Input or Holding	76	UInt16
Tariff 1 - Volume (Unit)	30078 or 40078	Input or Holding	77	8 char ASCII
Tariff 1 - Volume (Unit code)	30082 or 40082	Input or Holding	81	UInt16
Tariff 1 - Volume (Float)	30083 or 40083	Input or Holding	82	IEEE 754
Tariff 2 - Energy	30085 or 40085	Input or Holding	84	Int32
Tariff 2 - Energy (Coefficient)	30087 or 40087	Input or Holding	86	UInt16
Tariff 2 - Energy (Unit)	30088 or 40088	Input or Holding	87	8 char ASCII
Tariff 2 - Energy (Unit code)	30092 or 40092	Input or Holding	91	UInt16
Tariff 2 - Energy (Float)	30093 or 40093	Input or Holding	92	IEEE 754
Tariff 2 - Volume	30095 or 40095	Input or Holding	94	Int32
Tariff 2 - Volume (Coefficient)	30097 or 40097	Input or Holding	96	UInt16
Tariff 2 - Volume (Unit)	30098 or 40098	Input or Holding	97	8 char ASCII
Tariff 2 - Volume (Unit code)	30102 or 40102	Input or Holding	101	UInt16
Tariff 2 - Volume (Float)	30103 or 40103	Input or Holding	102	IEEE 754
Tariff 3 - Energy	30105 or 40105	Input or Holding	104	Int32
Tariff 3 - Energy (Coefficient)	30107 or 40107	Input or Holding	106	UInt16
Tariff 3 - Energy (Unit)	30108 or 40108	Input or Holding	107	8 char ASCII
Tariff 3 - Energy (Unit code)	30112 or 40112	Input or Holding	111	UInt16
Tariff 3 - Energy (Float)	30113 or 40113	Input or Holding	112	IEEE 754
Tariff 3 - Volume	30115 or 40115	Input or Holding	114	Int32
Tariff 3 - Volume (Coefficient)	30117 or 40117	Input or Holding	116	UInt16
Tariff 3 - Volume (Unit)	30118 or 40118	Input or Holding	117	8 char ASCII
Tariff 3 - Volume (Unit code)	30122 or 40122	Input or Holding	121	UInt16
Tariff 3 - Volume (Float)	30123 or 40123	Input or Holding	122	IEEE 754
Tariff 4 - Energy	30125 or 40125	Input or Holding	124	Int32
Tariff 4 - Energy (Coefficient)	30127 or 40127	Input or Holding	126	UInt16
Tariff 4 - Energy (Unit)	30128 or 40128	Input or Holding	127	8 char ASCII
Tariff 4 - Energy (Unit code)	30132 or 40132	Input or Holding	131	UInt16
Tariff 4 - Energy (Float)	30133 or 40133	Input or Holding	132	IEEE 754
Tariff 4 - Volume	30135 or 40135	Input or Holding	134	Int32
Tariff 4 - Volume (Coefficient)	30137 or 40137	Input or Holding	136	UInt16
Tariff 4 - Volume (Unit)	30138 or 40138	Input or Holding	137	8 char ASCII
Tariff 4 - Volume (Unit code)	30142 or 40142	Input or Holding	141	UInt16
Tariff 4 - Volume (Float)	30143 or 40143	Input or Holding	142	IEEE 754
Pulse input 1 - Volume	30145 or 40145	Input or Holding	144	Int32
Pulse input 1 - Volume (Coefficient)	30147 or 40147	Input or Holding	146	UInt16
Pulse input 1 - Volume (Unit)	30148 or 40148	Input or Holding	147	8 char ASCII
Pulse input 1 - Volume (Unit code)	30152 or 40152	Input or Holding	151	UInt16
Pulse input 1 - Volume (Float)	30153 or 40153	Input or Holding	152	IEEE 754
Pulse input 2 - Volume	30155 or 40155	Input or Holding	154	Int32
Pulse input 2 - Volume (Coefficient)	30157 or 40157	Input or Holding	156	UInt16
Pulse input 2 - Volume (Unit)	30158 or 40158	Input or Holding	157	8 char ASCII
Pulse input 2 - Volume (Unit code)	30162 or 40162	Input or Holding	161	UInt16
Pulse input 2 - Volume (Float)	30163 or 40163	Input or Holding	162	IEEE 754



Description	Modbus register	Type register	Modbus address	Type of data
Error code	30165 or 40165	Input or Holding	164	Hex
Meter ID no.	30166 or 40166	Input or Holding	165	UInt32
Meter ID (ASCII)	30168 or 40168	Input or Holding	167	8 char ASCII
Periodical Log 0 - Date - Jour	30172 or 40172	Input or Holding	171	UInt16
Periodical Log 0 - Date - Month	30173 or 40173	Input or Holding	172	UInt16
Periodical Log 0 - Date - Year	30174 or 40174	Input or Holding	173	UInt16
Periodical Log 0 - Energy	30175 or 40175	Input or Holding	174	Int32
Periodical Log 0 - Energy (Coefficient) <sup>1</sup>	30177 or 40177	Input or Holding	176	UInt16
Periodical Log 0 - Energy (Unit)	30178 or 40178	Input or Holding	177	8 char ASCII
Periodical Log 0 - Energy (Unit code)	30182 or 40182	Input or Holding	181	UInt16
Periodical Log 0 - Energy (Float)	30183 or 40183	Input or Holding	182	IEEE 754
Periodical Log 0 - Volume	30185 or 40185	Input or Holding	184	Int32
Periodical Log 0 - Volume (Coefficient)	30187 or 40187	Input or Holding	186	UInt16
Periodical Log 0 - Volume (Unit)	30188 or 40188	Input or Holding	187	8 char ASCII
Periodical Log 0 - Volume (Unit code)	30192 or 40192	Input or Holding	191	UInt16
Periodical Log 0 - Volume (Float)	30193 or 40193	Input or Holding	192	IEEE 754
Module serial no.	32001	Input	2000	UInt32
Module product no.	32003	Input	2002	Unit32
Software version	32005	Input	2004	Unit16

1	The integer value for the same group of registers (e.g. energy) must be multiplied by the unit factor to obtain the valid output value. Floating-point values do not need to be multiplied by the unit factor.
2	The unit of the value is indicated in the appropriate registers containing the unit name or unit ID.
3	Available values for unit ID registers are listed in the unit ID lookup table.
4	This register contains the temperature to one decimal place. To obtain the value in degrees, the contents of this register must be multiplied by 0.1.
5	Available values are listed in the error code list.
6	The meter's identification number is its secondary address. By default, this number is equal to the meter's serial number. This number can be modified by the user. Information on how to read the secondary address is provided in chapter 6.1.

### 6.2.2 CONFIGURATION REGISTERS

Description	Modbus register	Register type	Modbus address	Type of data	Value by default	Possible values
Address Slave ID <sup>1,2</sup>	41001	Holding company	1000	UInt16	0x0101	0xHHLL for which HH = 0x01 or 0x00 LL = 0x01 - 0xF7
Meter data update period <sup>3,4</sup>	41002	Holding company	1001	UInt16	600	0 - 65535
Transmission speed	41003	Holding company	1002	UInt32	9600	1200, 2400, 4800, 9600, 14400, 19200, 38400, 56000, 57600, 115200

Number of data bits	41005	Holding company	1004	UInt16	8	8
Parity bit <sup>5</sup>	41006	Holding company	1005	1 char ASCII	78 ('N')	110 ('n'), 111 ('o'), 101 ('e'), 78 ('N'), 79 ('O'), 69 ('E')
Number of stop bits	41007	Holding company	1006	UInt16	1	1, 2
Enable Periodical Log <sup>6</sup>	41008	Holding company	1007	UInt16	0	0, 1

1	The lower byte of this register (LL) represents the module slave ID in the range 1 to 247 (0x01 to 0xF7 in hexadecimal).
2	If Higher byte is set to 1, the slave ID will be updated with the heat meter serial number. If Higher byte is set to 0, the slave ID remains static.
3	The default update rate is 60 seconds. When the update rate is set to 0, the module does not read heat meter data.
4	This register contains a time value with an accuracy of one decimal place. Therefore, a Modbus register value of 600 means 60.0 seconds.
5	This register is defined by the ASCII value of the character: 'E' for even parity (69 decimal, 0x45 hexadecimal), 'O' for odd parity (79 decimal, 0x4F hexadecimal) and 'N' for no parity (78 decimal, 0x4E hexadecimal).
6	For further information, see section 6.5 "Periodic log 0 functionality".

### 6.2.3 INFORMATION REGISTERS

Description	Modbus register	Modbus register type	Modbus address	Data type	Read only (RO) Read/write (R/W)
Module serial number	32001	Input	2000	UInt32	RO
Module model number	32003	Input	2002	UInt32	RO
Module firmware version <sup>1</sup>	32005	Input	2004	UInt16	RO

1	Higher byte of the register is major number of firmware version (0x##00 hex). Lower byte of the register is minor number of firmware version (0x00## hex).
---	--

### 6.3 UNIT ID TABLE

Each group of measurement data registers contains information about the units. This information is stored in two registers:

- Unit name: unit in human-readable ASCII format,
- Unit ID: unit identification number.

All available Unit IDs with their appropriate names are listed in the table below:

Code	Name	Code	Name	Code	Name	Code	Name	Code	Name
0	No	10	callus	20	m <sup>3</sup>	30	kGal/min	40	GBtu/h
1	mWh	11	kcal	21	mGal	31	MGal/min	41	°C
2	Wh	12	Mcal	22	Gal	32	mW	42	°F
3	kWh	13	Gcal	23	kGal	33	W		
4	MWh	14	Btu	24	MGal	34	kW		
5	GWh	15	kBtu	25	ml/h	35	MW		
6	J	16	MBtu	26	l/h	36	GW		
7	kJ	17	GBtu	27	m <sup>3</sup> /h	37	Btu/h		
8	MJ	18	ml	28	mGal/min	38	kBtu/h		
9	GJ	19	l	29	Gal/min	39	MBtu/h		

### 6.4 CALCULATION EXAMPLE

This example shows how to read and interpret the measurement data in the module's Modbus registers, based on the energy value. Energy measurement data, read from the meter by the module, are stored in 10 Modbus registers, available from Modbus address 30001 or 40001 (Modbus address 0).

In this example, the module is installed in the meter with the serial number 51241026, and the automatic slave identification feature is activated, so the module's slave ID is 26 (0x1A).

To request the Modbus module as a master with slave ID 26 (0x1A), you must use the following Modbus request function:

Slave ID	Code	Modbus address of first group register	Modbus register group size	CRC
0x1A	0x04	0x0000	0x000A	0x73E6

The module answers :

Slave ID	Code	Number of data bytes to track	Raw data read from the					CRC
0x1A	0x04	0x14	0x0000	0x3039	0x0001	0x4D4A	0x0000	0x7246
			0x0000	0x0000	0x0008	0x4640	0xE400	

The raw data in hexadecimal (hex) format received from the module are listed in the table below.

Counter display value	Modbus register (Modbus address)	Register value in hexadecimal	Modbus register (Modbus address) data	Type	Value in hexadecimal	Value
	30001 or 40001 (0)	0x0000	Energy - 30001 or 40001 (0)	Int32	0x00003039	12,345
	30002 or 40002 (1)	0x3039				
	30003 or 40003 (2)	0x0001	Energy (Unit) - 30003 or 40003 (2)	UInt16	0x0001	1
	30004 or 40004 (3)	0x4D4A	Energy (unit name) 30004 or	8 char ASCII	0x4D4A0000 00000000	MJ
	30005 or 40005 (4)	0x0000				

	30006 or 40006 (5)	0x0000	40004 (3)			
	30007 or 40007 (6)	0x0000				
	30008 or 40008 (7)	0x0008	Energy (Unit ID) 30008 or 40008 (7)	UInt16	0x0008	8
	30009 or 40009 (8)	0x4640	Energy (Floating) - 30009 or 40009 (8)	IEEE 754	0x4640E400	12,345
	30010 or 40010 (9)	0xE400				

To read the energy value in fixed-point data format, the following calculation must be performed  
 Energy value = Energy register \* Unit factor register [Unit name register].  
 For example, if the energy register contains the value 12 345 and the unit factor register contains the value 1 MJ, then :

Energy value = 12,345 \* 1 MJ = 12,345 MJ = 12.345 GJ

The energy value in floating-point data format can be read directly:

Floating energy value = 12,345 MJ = 12.345 GJ

The unit name is presented in human-readable ASCII format, or can be obtained from the unit ID look-up table. In this example, the unit ID register shows the value 8, which means that the unit of value is MJ (megajoule).

**NOTE:**



Pay attention when using floating-point type values according to IEEE 754. Floating-point values are calculated by the module based on fixed-point values data from the meter. When using floating-point values, precision can be lost and value presented in Modbus register may not be equal to value on meter display. It is recommended to use fixed-point value (Int32 and UInt16) Modbus registers to read always proper data. The floating-point values are introduced in the module just for convenience, when additional calculations cannot be done by Modbus master application.

**6.5 PERIODIC LOG FUNCTIONALITY 0**

The Modbus RTU communication module has functionality to read the meter's periodic log 0 data and update the appropriate Modbus registers with the associated energy, volume and dates (Modbus addresses 171 to 192).



**NOTE :**

Periodical Log 0 functionality is disabled in Modbus RTU Communication Module by default.

To enable or disable the Periodic Log 0 feature, write data to Modbus register 41008 (Modbus address 1007). This feature allows you to read only a single block of data (data block 0) from the periodic log memory into the counter. The permitted values for the Periodic Log 0 enable register are listed in the table below.

Periodical Log 0 functionality	Enable Periodical Log 0 data register value	Description
Disabled	0 (0x00 hex)	Periodic Log 0 registers contain invalid values.
Enabled	1 (0x01 hex)	The Modbus registers at addresses 171 to 192 contain the values read from the counter's Periodic Log 0 data.

Please note that enabling this option may change default readout from the meter by M-Bus protocol. By default, the module reads data from the meter without defining the response (selecting Application Reset-Subcode) – default telegram is sent to the meter (if not special telegram content is agreed). After enabling Periodical Log 0 functionality the module reads data from the meter with responses from Application Reset-Subcodes: 0x00 (All) and 0x40 (Multi tariff billing). Disabling Periodical Log 0 functionality results in data readout with Application Reset-Subcode 0x00 (All) without returning to default telegram.

### 6.6 ERROR CODES

In the Modbus RTU Communication Module, error codes are stored in Modbus register 30165 or 40165 (Modbus address 164). This register contains information on the communication status between the module and the meter, and shows errors read directly from the meter.

Description	Meter error code	Error code in Modbus register n° 30165 or 40165	Priority
No error	-	0x00 00	-
No communication with the meter	-	0x01 00	1
Damaged basic parameter values in memory Flash or RAM	C-1	0x00 08	2
No mains supply (if meter power module is used) -> Battery backup power supply	E-8	0x00 04	3
Flow measurement error Damaged transmitter -> Transducer short-circuit	E-4	0x00 28	4
Temperature value out of range [-9.9°C ... 190°C]. -> Short-circuit in temperature sensor or cut temperature sensor cable	E-1	0x00 50	5
Flow measurement error -> Air in flow sensor	E-7	0x00 70	6
Battery empty	E-9	0x00 84	7
Negative temperature difference or incorrectly installed temperature sensors	E-3	0x00 B0	8
Wrong direction of water flow through meter -> Flow = 0	E-6	0x00 D0	9
Leak detected	Leakage error	0x00 F0	10
Data buffer overflow, communication with thermal energy meter impossible -> Set an upper period value in the register Modbus 41002	E-5	0x00 10	11



**NOTE :**

Only one error per priority is displayed at a time.

## 6.7 MODBUS CONFIGURATOR SOFTWARE

The Modbus RTU module can be configured using the dedicated *Modbus Configurator* software. Contact Diehl Metering to obtain it.

## 7 RESTORE TO DEFAULT SETTINGS

To restore the Modbus RTU Communication Module to default settings, press the module's pushbutton for at least 15 seconds. Restoration is confirmed by the status LED flashing. All configuration registers are reset to default values.

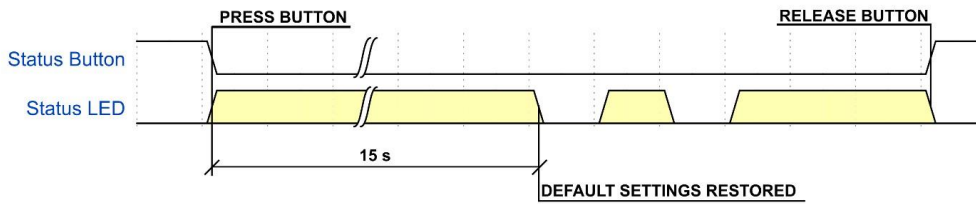

Figure 11 Process of restoring to default settings

The restore default settings function is useful when the currently configured communication parameters are unknown.



**NOTE :**

If the Modbus RTU communication module is connected to the meter while the default settings are being restored, its Modbus slave ID will be automatically updated according to the meter's serial number.

## 8 TROUBLESHOOTING GUIDE

If the Modbus RTU communication module does not seem to be working properly, please refer to the following table.

Symptom	Possible cause	Action to solve the problem
Device does not respond to Modbus requests	The module is not powered correctly	Check power supply connection
	Incorrect EIA-485 wiring	Check EIA-485 connection
	Incorrect Modbus communication parameters	Check communication parameters - slave ID, baud rate, number of parity bits and number of stop bits. If the module's current communication parameters are unknown, restore the module's default settings.

	Incorrect Modbus addressing	Ensure that the slave ID is unique for each device on the network. Make sure there is only one Modbus master on the network. If the current slave ID of the module is unknown, restore the default settings of the. Check the slave ID number when it is automatically set according to the secondary address/serial number of the counter.
Unable to read values from meter	Module ribbon cable connection to meter broken	Check module connector. If the module connector is broken, replace it with a new one.
	The update rate register is set to 0	Check the value of the update rate register. If it is set to 0, change it.
	Meter display shows error code 5	This problem only exists when the drive is powered of the battery. Make sure the update interval is greater than 3 minutes (for more information, refer to the SHARKY 775 or SCYLAR INT 8 installation and user guides).
Cannot close meter housing	The module is incorrectly installed	Reinstall the module in the dedicated slot.
	Inadequate wires	Check that there is enough space inside the housing to accommodate the module and wires.
Status LED lights on constantly	Application fault	Contact supplier for more information.

## 9 DECLARATION OF CONFORMITY

The module is complaint with European Union harmonization legislation and standards for Information Technology Equipment as stated in the EU Declaration of Conformity below.

<p><b>DOC-DM-MBRTU-01</b></p> <p>EN EU declaration of conformity                  DE EU-Konformitätserklärung                  ES Declaración UE de conformidad                  PT Declaração UE de conformidade</p> <p><b>1., 4.</b>                  EN Product / Object of the declaration                  DE Produkt / Gegenstand der Erklärung                  ES Producto / Objeto de la declaración                  PT Produto / Objeto da declaração</p> <p style="text-align: center;"><b>Modbus RTU Module, Product Number: DM-MBRTU, Model Number: 21010</b></p> <p><b>2.</b>                  EN Manufacturer                  DE Hersteller                  ES Fabricante                  PT Fabricante</p> <p style="text-align: center;"><b>NOITAC spółka z ograniczoną odpowiedzialnością sp.k.                  ul. Szlak 28/3                  PL-31153 Kraków                  Poland</b></p> <p><b>3.</b>                  EN This declaration of conformity is issued under the sole responsibility of the manufacturer.                  DE Die alleinige Verantwortung für die Ausstellung dieser Konformitätserklärung trägt der Hersteller.                  ES La presente declaración de conformidad se expide bajo la exclusiva responsabilidad del fabricante.                  PT A presente declaração de conformidade é emitida sob a exclusiva responsabilidade do fabricante.</p> <p><b>5.</b>                  EN The object of the declaration described above is in conformity with the relevant Union harmonisation legislation:                  DE Der oben beschriebene Gegenstand der Erklärung erfüllt die einschlägigen Harmonisierungsrechtsvorschriften der Union:                  ES El objeto de la declaración descrita anteriormente es conforme con la legislación de armonización pertinente de la Unión:                  PT O objeto da declaração acima descrito está em conformidade com a legislação de harmonização da União aplicável:</p> <p style="text-align: center;"><b>2011/65/EU (2011 OJ L 174, 1.7.2011)                  2014/30/EU (2014 OJ L 96, 29.3.2014)</b></p>	<p style="text-align: right; font-size: 24px; font-weight: bold; margin-bottom: 20px;">NOITAC</p> <p>PL Deklaracja zgodności UE                  FR Déclaration UE de conformité                  NL EU-conformiteitsverklaring</p> <p>PL Produkt / Przedmiot deklaracji                  FR Produit / Objet de la déclaration                  NL Product / Voorwerp van de verklaring</p> <p>PL Producent                  FR Fabricant                  NL Fabrikant</p> <p>PL Niniejsza deklaracja zgodności wydana zostaje na wyłączną odpowiedzialność producenta.                  FR La présente déclaration de conformité est établie sous la seule responsabilité du fabricant.                  NL Deze conformiteitsverklaring wordt verstrekt onder volledige verantwoordelijkheid van de fabrikant.</p> <p>PL Wymieniony powyżej przedmiot niniejszej deklaracji jest zgodny z odnośnymi wymaganiami unijnego prawodawstwa harmonizacyjnego:                  FR L'objet de la déclaration décrit ci-dessus est conforme à la législation d'harmonisation de l'Union applicable:                  NL Het hierboven beschreven voorwerp is in overeenstemming met de desbetreffende harmonisatiewetgeving van de Unie:</p>
DOC-DM-MBRTU-01	Page 1 of 2



6.

- EN References to the relevant harmonised standards or normative documents used or references to the other technical specifications in relation to which conformity is declared:
- DE Bezugnahme auf die entsprechenden harmonisierten Normen oder normativen Dokumente, die zugrunde gelegt wurden, oder auf andere technischer Spezifikationen, für die die Konformität erklärt wird:
- ES Referencias a las normas armonizadas o documentos normativos pertinentes utilizados, o referencias a las otras especificaciones técnicas respecto a las cuales se declara la conformidad:
- PT Referências às normas harmonizadas aplicáveis ou aos documentos normativos utilizados ou às outras especificações técnicas em relação às quais é declarada a conformidade:

EN 50581:2012  
EN 55032:2015  
EN 55032:2015/A11 :2020

- PL Odniesienia do odpowiednich norm zharmonizowanych lub odpowiednich dokumentów normatywnych, które zastosowano, lub do innych specyfikacji technicznych, w odniesieniu do których deklarowana jest zgodność:
- FR Références des normes harmonisées ou des documents normatifs pertinents appliquées ou des autres spécifications techniques par rapport auxquelles la conformité est déclarée:
- NL Vermelding van de toegepaste relevante geharmoniseerde normen of normatieve documenten of van andere technische specificaties waarop de conformiteitsverklaring betrekking heeft:

EN 55035 :2017  
EN 55035:2017/A11:2020  
EN 61000-3-2:2014  
EN 61000-3-3:2013

8.

- EN Signed for and on behalf of:
- DE Unterzeichnet für und im Namen von:
- ES Firmado en nombre de:
- PT Assinado por e em nome de :

- PL Podpisano w imieniu:
- FR Signé par et au nom de :
- NL Ondertekend voor en namens:

NOITAC spółka z ograniczoną odpowiedzialnością sp.k.  
Kraków, 2020-12-11



Mateusz Niedzielski



Filip Dudek

Diehl Metering  
67 rue du Rhône  
68300 Saint-Louis  
France  
Tel: + 33 (0)3 89 69 54 00  
Fax: +33 (0)3 89 69 72 20  
E-Mail: [info-dmfr@diehl.com](mailto:info-dmfr@diehl.com)

[www.diehl.com/metering](http://www.diehl.com/metering)